

FUEL SYSTEM

SERVICE INSTRUCTION WORKSHEET

TO REPAIR GF3/18-6

CARTER CARBURETOR

2 BARREL - BBD 1 1/4 (LATE)

TYPICAL ILLUSTRATION

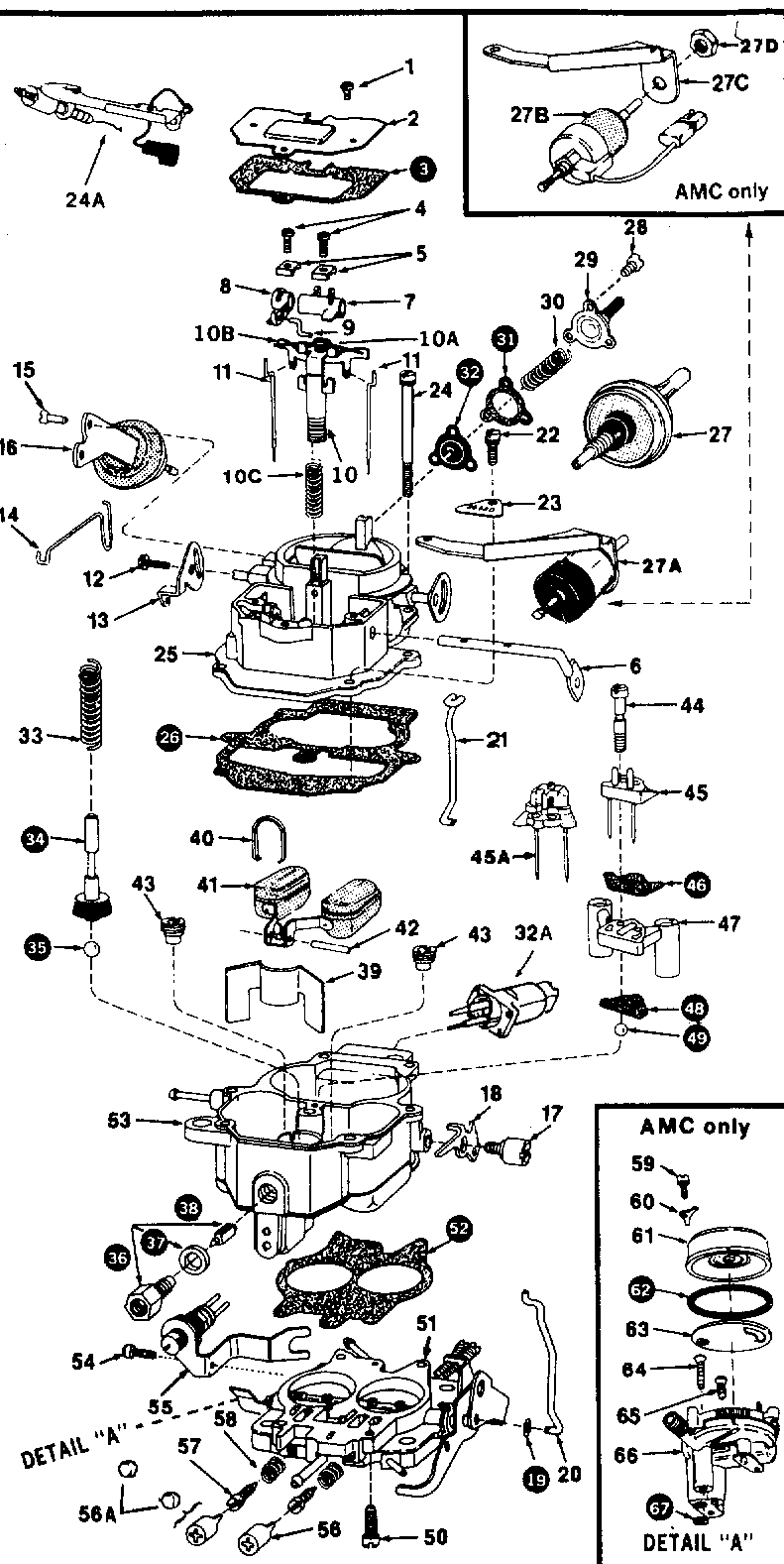

1. Carefully read the text in the following pages to become familiar with the contents of this worksheet before performing carburetor overhaul.
2. The exploded view shown is typical of the model carburetor this kit will service. The view may differ slightly from the actual carburetor being overhauled.
3. Use the exploded view as a guide. The numerical sequence may generally be followed to disassemble the carburetor far enough to permit cleaning and inspection.
4. Parts list shown DOES NOT reflect the contents of the kit.

CLEANING

Cleaning must be done with carburetor disassembled. Cover opening on intake manifold after carburetor is removed. Soak parts in cleaning solvent long enough to soften foreign matter.
Caution: Do not soak parts made of rubber, leather, plastic or electrical parts. Remove all loose particles and dirt using a brush. Do not use abrasives. Do not use a metal wire to clean out passageways and jets. Wash off in suitable solvent. Clear all passageways and jets with compressed air.

PARTS LIST

- | | |
|-------------------------------------|---------------------------------------------------------------|
| 1. Dust Cover Screw (3) | 32A. Duty Cycle Solenoid* |
| 2. Dust Cover | 33. Plunger Spring |
| 3. Dust Cover Gasket | 34. Plunger Assembly |
| 4. Pump/Metering Rod Screws (2) | 35. Intake Check Ball (Large) |
| 5. Pump/Metering Rod Washers (2) | 36. Seat |
| 6. Pump Counter Shaft | 37. Gasket Assembly |
| 7. Metering Rod Arm | 38. Needle |
| 8. Pump Arm | 39. Baffle |
| 9. Pump Link | 40. Float Pin Retainer |
| 10. Step-Up Piston Assy. | 41. Float Assembly |
| 10A. Step-Up Piston Adj. Screw | 42. Float Pin |
| 10B. Step-Up Piston Spring | 43. Main Metering Jet (2) |
| 10C. Vacuum Piston Spring | 44. Venturi Screw (2) |
| 11. Metering Rod (2) | 45. Venturi Cover Assembly |
| 12. Choke Shaft Lever Screw | 45A. Venturi Cover |
| 13. Choke Shaft Lever | 46. Venturi Cover Gasket |
| 14. Choke Pulloff Rod | 47. Venturi Assembly |
| 15. Choke Pulloff Bracket Screw | 48. Venturi Gasket |
| 16. Choke Pulloff | 49. Check Ball (small) |
| 17. Fast Idle Cam Screw | 50. Body Flange Screw (4) |
| 18. Fast Idle Cam | 51. Body Flange |
| 19. Retainer | 52. Body Flange Gasket |
| 20. Throttle Connector Rod | 53. Main Body Casting |
| 21. Fast Idle Rod | 54. E.G.R. Dump Valve Screw |
| 22. Bowl Cover Screw (4) | 55. E.G.R. Dump Valve/Bracket |
| 23. Carburetor Tag I.D. | 56. Limiter Cap (2)* |
| 24. Bowl Cover & Bracket Screw (2) | 56A. Idle Mixture Screw Plug (2)
(See Fig. J -Some Models) |
| 24A. Transducer & Idle Ground Post* | 57. Idle Mixture Screw (2) |
| 25. Bowl Cleaner | 58. Idle Mixture Spring (2) |
| 26. Bowl Cover Gasket | 59. Thermostat Cover Screw (2) |
| 27. Vacuum Throttle Positioner | 60. Thermostat Cover Retainer |
| 27A. AMC: Solenoid & Bracket Assy. | 61. Thermostat Cover |
| 27B. Solenoid | 62. Thermostat Cover Gasket |
| 27C. Bracket | 63. Baffle Plate |
| 27D. Locknut | 64. Choke Housing Screw (long) |
| 28. Idle Cover Screw (3) | 65. Choke Housing Screw (short) |
| 29. Idle Enrichment Cover | 66. Choke Housing |
| 30. Idle Enrichment Spring | 67. Choke Housing Gasket |
| 31. Idle Enrichment Gasket | |
| 32. Idle Enrichment Diaphragm | |

NOTE: Circled parts are included in most kits. Extra parts are included for other kits.

☞ PARTS LIST SHOWN DOES NOT REFLECT THE CONTENTS OF THE KIT.

DISASSEMBLY -- ASSEMBLY NOTES

1. UPON DISASSEMBLY, MARK LOCATION & NOTE POSITION OF ALL SPRINGS WHICH HAVE TO BE REMOVED.
2. RETAIN ALL OLD GASKETS FOR MATCHING PURPOSES.
3. WHEN REMOVING MIXTURE SCREWS (57) MARK POSITION, TURN UNTIL LIGHTLY SEATED COUNTING NUMBER OF TURNS, TURN OUT TO INDEX MARK. RECORD NUMBER OF TURNS FOR RE-ASSEMBLY AND THEN REMOVE.
4. SOME MODELS: REMOVE LIMITER CAPS (56) BY TURNING IN #8 SHEET METAL SCREW IN CENTER OF CROSS SLOTS FORCING LIMITER CAPS OFF.

5. BE SURE RETAINER (40) IS SEATED ON FLOAT PIN (42) AND NOT HUNG UP IN GUIDE SLOTS.
6. LIGHTLY LUBRICATE PLUNGER ASSEMBLY CUP (34) BEFORE INSTALLING.
7. DO NOT ALLOW VITON NEEDLE (38) TO BE PRESSED INTO SEAT (36).
8. CHECK THROTTLE LINKAGE FOR FREEDOM OF MOVEMENT BEFORE & AFTER INSTALLATION OF CARBURETOR ON ENGINE.

ADJUSTMENT DATA

**FIG. A
FLOAT LEVEL ADJUSTMENT**

1. INVERT MAIN BODY SO THAT ONLY WEIGHT OF FLOATS IS FORCING NEEDLE AGAINST SEAT.
2. HOLD FINGER AGAINST RETAINER TO ASSURE PIN IS FULLY SEATED.
3. MEASURE FROM THE SURFACE TO THE FUEL BOWL TO THE CROWN AT CENTER OF EACH FLOAT.
4. TO ADJUST, BEND TAB ON FLOAT ARM.

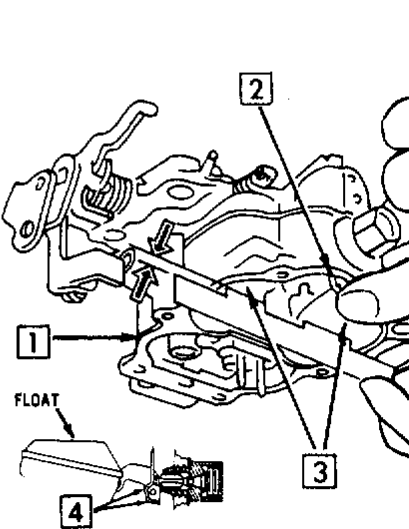

**FIG. D
BOWL VENT ADJUSTMENT**

NOTE: PUMP TRAVEL AND CURB IDLE SPEED MUST BE PROPERLY SET BEFORE MAKING THIS ADJUSTMENT.

1. MEASURE BETWEEN TOP OF BOWL VENT VALVE AND SEAT.
2. ADJUST TO SPECIFIED CLEARANCE BY BENDING THE BOWL VENT LEVER TAB.

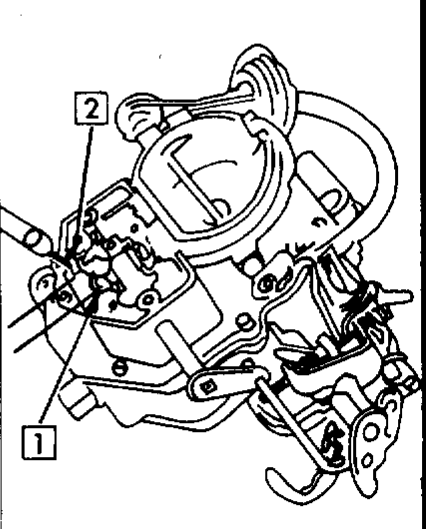

STEP I BASIC ADJUSTMENT

1. WITH STEP-UP PISTON ASSY. OUTSIDE CARBURETOR, MEASURE GAP CLEARANCE AS SHOWN & RECORD. IF SETTING APPEARS INCORRECT, TURN SCREW TO ADJUST GAP CLEARANCE AS SPECIFIED (SEE SPEC. CHART) OR APPROX. 1/32". NOTE: TURN ADJUSTING SCREW IN TO DECREASE GAP CLEARANCE ALLOWING METERING RODS TO LIFT FURTHER OUT OF MAIN JETS TO ENRICHEN MIXTURE. TURN ADJUSTING SCREW OUT FOR OPPOSITE EFFECT.

FIG. B -- STEP-UP PISTON ADJUSTMENT

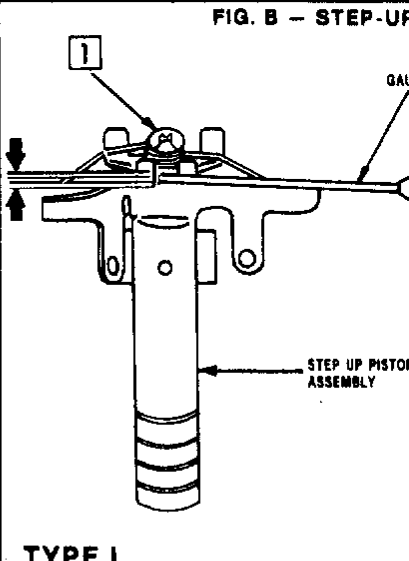

TYPE I

STEP II REQUIRED ADJUSTMENT

NOTE: WITH STEP-UP PISTON ASSY. INSTALLED IN CARBURETOR, TURN OUT IDLE R.P.M. SCREW UNTIL THROTTLE VALVES ARE COMPLETELY CLOSED.

1. FULLY DEPRESS STEP-UP PISTON WHILE HOLDING MODERATE PRESSURE ON ROD LIFTER TAB.
2. NEXT, TIGHTEN ROD LIFTER LOCK SCREW, THEN RETURN IDLE R.P.M. SCREW TO ITS ORIGINAL SETTING.

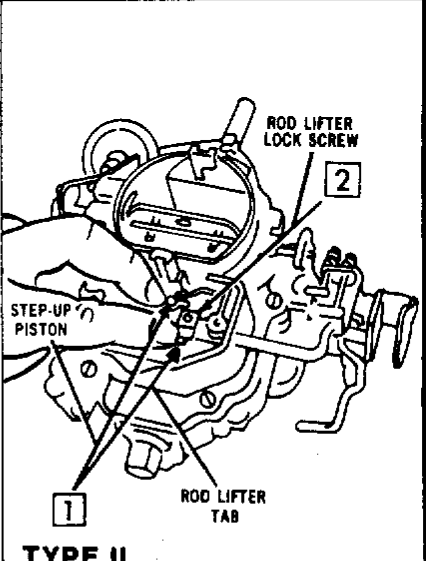

TYPE II

**FIG. C
PUMP TRAVEL**

NOTE: PLACE PUMP LINK IN OUTER HOLE OF PUMP ARM AND TURN CURB IDLE SCREW TWO FULL TURNS CLOCKWISE AFTER IT JUST CONTACTS STOP. HOLD THROTTLE IN CLOSE POSITION.

1. MEASURE FROM THE TOP OF ACCELERATOR PUMP SHAFT TO TOP OF BOWL COVER.
2. TO ADJUST, LOOSEN PUMP SHAFT LOCK SCREW AND ROTATE SLEEVE UNTIL PROPER DISTANCE IS OBTAINED.

CHRYSLER MODELS: IF PUMP TRAVEL IS CHANGED, BOWL VENT ADJUSTMENT MUST BE RESET.

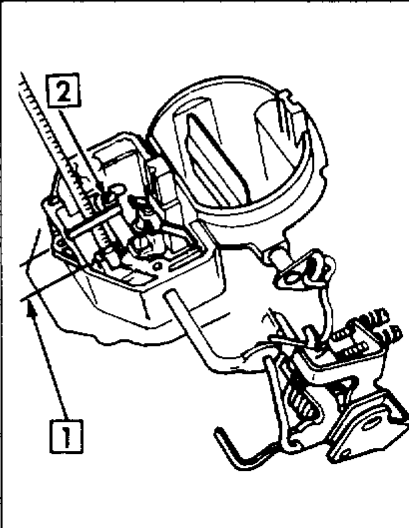

**FIG. E
UNLOADER**

1. HOLD THROTTLE VALVE IN WIDE OPEN POSITION.
2. LIGHTLY CLOSE CONTROL LEVER TO MOVE CHOKE VALVE TOWARD CLOSED POSITION.
3. MEASURE BETWEEN TOP OF CHOKE VALVE AND AIR HORN WALL.
4. ADJUST BY BENDING TANG ON THROTTLE LEVER.

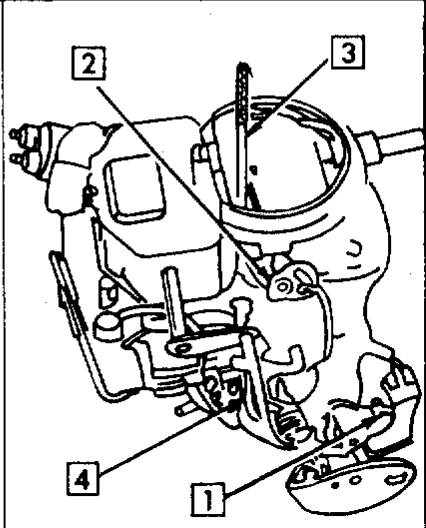

**FIG. F
AUTO CHOKE**

1. ROTATE COVER AGAINST SPRING TENSION. ALIGN INDEX MARK TO SPECIFIED SETTING ON CHOKE HOUSING.

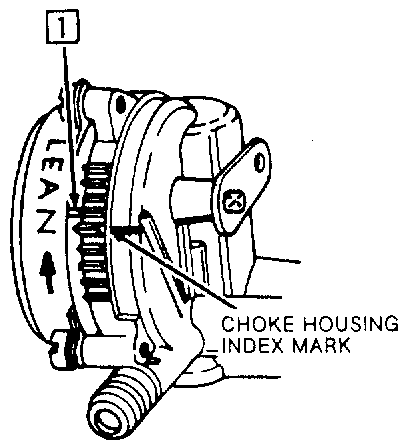

**FIG. H
FAST IDLE LINK**

1. PLACE FAST IDLE SPEED SCREW ON APPROPRIATE STEP OF CAM.
2. MOVE CHOKE VALVE TOWARD CLOSED POSITION WITH LIGHT PRESSURE ON CHOKE SHAFT LEVER.
3. MEASURE BETWEEN UPPER EDGE OF CHOKE VALVE AND INNER WALL OF AIR HORN.
4. TO ADJUST, BEND CHOKE LINK.

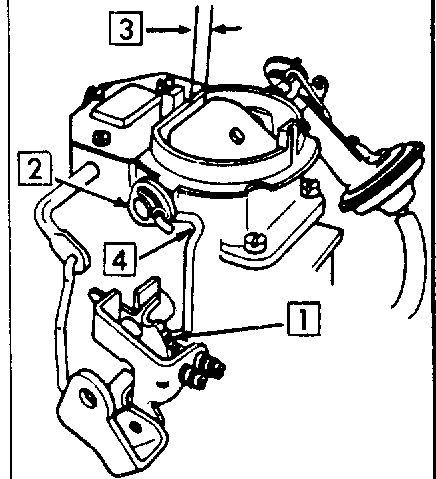

**FIG. G
CHOKE DIAPHRAGM LINK
(CHOKE PULL OFF)**

NOTE: AMER. MOTORS ONLY - ROTATE CHOKE COVER 90° RICH.

1. APPLY AT LEAST 15" OF VACUUM FROM AN EXTERNAL SOURCE TO CHOKE DIAPHRAGM ASSEMBLY.
2. MEASURE AS SPECIFIED BETWEEN TOP EDGE OF CHOKE VALVE AND WALL OF AIR HORN.
3. TO ADJUST, BEND CHOKE LINK AS REQUIRED.

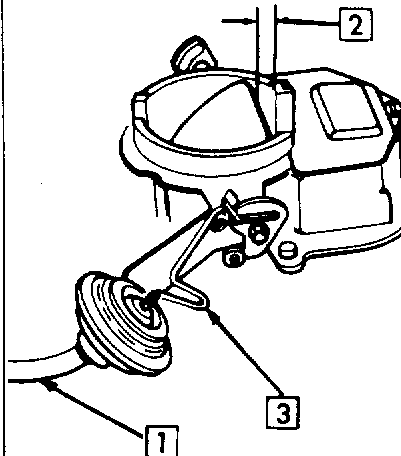

**FIG. I
DASHPOT
(VACUUM THROTTLE POSITIONER)**

NOTE: SOME MODELS USE VACUUM THROTTLE POSITIONER; OTHERS USE THROTTLE SOLENOID. REFER TO SHOP MANUAL OR ENGINE DECAL TO ADJUST THROTTLE SOLENOID.

1. MANUALLY POSITION THROTTLE LEVER TO 2500 RPM.
2. LOOSEN LOCK NUT.

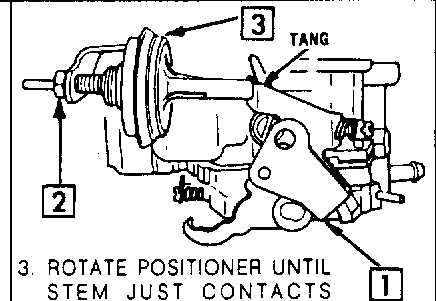

3. ROTATE POSITIONER UNTIL STEM JUST CONTACTS TANG. RELEASE THROTTLE LEVER AND SLOWLY ROTATE POSITIONER TO DECREASE ENGINE SPEED UNTIL A SUDDEN DROP OCCURS (ABOVE 1000 RPM). NOW TURN POSITIONER IN THE DECREASING DIRECTION AN ADDITIONAL 1/4 TURN, AND TIGHTEN LOCK NUT.

PUMP CHECK BALL LOCATION

NOTE: CHECK BALLS MUST BE INSTALLED IN THEIR PROPER LOCATIONS. FAILURE TO DO SO WILL CAUSE HARD STARTING AND OR INABILITY TO ACCELERATE.

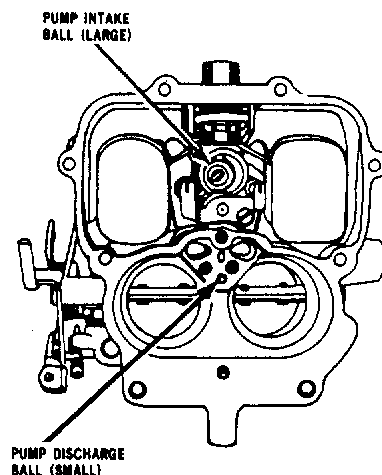

**FIG. J
REMOVAL OF IDLE MIXTURE PLUGS & SCREWS**

1. DRILL SMALL HOLE IN CENTER OF EACH PLUG. USE AN APPROPRIATE PULLER OR TOOL SUCH AS A BENT PICK TO REMOVE BOTH PLUGS.
2. TO REMOVE MIXTURE SCREWS, MARK POSITION THEN TURN IN TO SEAT LIGHTLY. TURN OUT COUNTING NUMBER OF TURNS TO INDEX MARK. RECORD & REMOVE.

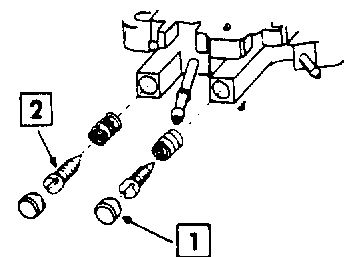

SPECIFICATIONS BY APPLICATION

Year	MODEL	Float Level Fig. A	Step-Up Piston Adjust. Fig. B	Pump Travel Fig. C	Bowl Vent Fig. D	Un-loader Fig. E	Auto. Choke Setting Fig. F	Choke Diaph. Link Fig. G	Dash-pot Fig. I	Fast Link Fig. I	Idle Speed	
											Hot	Fast

AMC — SPECIFICATION I.D.-B

87-82	258 Eng. Carb. No. 8338, 39, 60, 62, 64, 67, 83, 84 Carb. No. 8349	1/4	1/32	33/64	—	9/32	1 Rich ¹	9/64	See Text	3/32	—	—	
		1/4	1/32	1/2	—	9/32	2 Rich	1/8	See Text	3/32	—	—	
1981	258 Eng. -A.T., M.T. -Calif.; A.T. -Hi-Alt. -A.T. -Fed. -M.T. -M.T. -Hi-Alt.	1/4	1/32	33/64	—	9/32	1 Rich	9/64	See Text	3/32	—	—	
		1/4	1/32	1/2	—	9/32	2 Rich	1/8	See Text	3/32	—	—	
		1/4	1/32	33/64	—	9/32	2 Rich	1/8	See Text	3/32	—	—	
		1/4	1/32	33/64	—	9/32	1 Rich	1/8	See Text	5/64	—	—	
1980	258 Eng. Carb. No. 8278 A.T. - Exc. Carb. No. 8253, 56, 57 A.T. - Exc. Carb. No. 8216, 46, 47, 48, 8313 M.T. - Exc. Carb. No. 8253, 56, 57 M.T. - Exc. Carb. No. 8216, 46, 47, 48, 8313	1/4	1/32	35/64	—	9/32	Index	9/64	—	3/32	—	—	
		1/4	1/32	33/64	—	9/32	2 Rich	9/64	See Text	3/32	600	1850	
		1/4	1/32	15/32	—	9/32	2 Rich	1/8	—	—	3/32	—	—
		1/4	1/32	33/64	—	9/32	1 Rich	5/32	See Text	3/32	700	1700	
		1/4	1/32	33/64	—	9/32	2 Rich	1/8	—	3/32	—	—	—
1979	258 Eng. -A.T. -M.T. -High Altitude -A.T. -Calif. -A.T. -High Altitude	1/4	1/32	15/32	—	9/32	1 Rich	9/64	—	7/64	700	1600	
		1/4	1/32	33/64	—	9/32	1 Rich	5/32	—	7/64	—	1500	
		1/4	1/32	15/32	—	9/32	1 Rich	9/64	—	7/64	—	1600	
		1/4	1/32	17/32	—	9/32	1 Rich	5/32	—	7/64	—	1600	
1978	258 Eng. -A.T. -M.T.	1/4	3/64	1/2	—	9/32	Index	5/32	—	7/64	700	1600	
		1/4	3/64	33/64	—	9/32	1 Rich	1/8	—	3/32	750	1500	
1977	258 Eng. -A.T. -Exc. Calif. -Calif. -M.T.	1/4	1/32	1/2 ¹⁷	—	9/32	2 Rich	5/32	7/64 ¹⁸	1/8	600	1600	
		1/4	1/32	1/2 ¹⁷	—	9/32	2 Rich	5/32	7/64 ¹⁸	7/64	700	1600	
		1/4	1/32	1/2 ¹⁷	—	9/32	1 Rich	1/8	7/64 ¹⁸	3/32	600	1600	
1976	258 Eng. -A.T. -M.T.	1/4	3/64	1/2 ¹⁷	—	1/4	2 Rich	1/8	7/64 ¹⁸	3/32 ¹⁹	700	1700	
		1/4	3/64	1/2 ¹⁷	—	1/4	1 Rich	1/8	7/64 ¹⁸	3/32 ¹⁹	850	1700	

JEEP

87-82	258 Eng. Carb. No. 8338, 39, 60, 62, 64, 67, 83, 84 Carb. No. 8340, 41 Carb. No. 8349	1/4	1/32	33/64	—	9/32	1 Rich	9/64	See Text	3/32	—	—
		1/4	1/32	33/64	—	9/32	1 Rich	5/32	See Text	7/64 ²	—	—
		1/4	1/32	1/2	—	9/32	2 Rich ³	1/8	See Text	3/32	—	—
1981	258 Eng. Carb. No. 8255 Carb. No. 8257 Carb. No. 8312 -A.T., M.T. -Calif.; A.T. -Hi-Alt. -A.T. -Fed. -M.T. -M.T. -Hi-Alt.	1/4	1/32	15/32	—	9/32	Index	9/64	—	3/32	—	—
		1/4	1/32	33/64	—	9/32	2 Rich	1/8	—	3/32	—	—
		1/4	1/32	1/2	—	9/32	1 Rich	9/64	—	3/32	—	—
		1/4	1/32	33/64	—	9/32	2 Rich	1/8	See Text	3/32	—	—
1980	258 Eng. -A.T. -Calif., Fed. -M.T. -Calif., Fed. Carb. No. 8255 -M.T. -Hi-Alt.	1/4	1/32	15/32	—	9/32	2 Rich	1/8	—	3/32	—	—
		1/4	1/32	33/64	—	9/32	2 Rich	1/8	—	3/32	—	—
		1/4	1/32	15/32	—	9/32	Index	9/64	—	3/32	—	—
		1/4	1/32	33/64	—	9/32	1 Rich	7/64	—	5/64	—	—
		1/4	1/32	33/64	—	9/32	2 Rich	1/8	—	3/32	750	1700
1979	258 Eng. -A.T. -M.T. -A.T. -M.T. -A.T. -Calif. -M.T. -Calif.	1/4	1/32	7/16	—	9/32	2 Rich	1/8	—	3/32	750	1700
		1/4	1/32	15/32	—	9/32	1 Rich	9/64	—	7/64	700	1600
		1/4	1/32	33/64	—	9/32	1 Rich	5/32	—	7/64	750	1600
		1/4	1/32	15/32	—	9/32	1 Rich	9/64	—	7/64	700	1600
		1/4	1/32	33/64	—	9/32	1 Rich	5/32	—	7/64	750	1600
78-77	258 Eng.	1/4	1/32	7/16	—	9/32	2 Rich	5/64	—	3/32	650	1650

CHRYSLER, DODGE, PLYMOUTH — SPECIFICATION I.D.-C

1984	318 Eng.	1/4	1/32	15/32	—	9/32	—	1/8	See Text	5/64	—	—
83-81	225 Eng. -A.T. -Can. 318 Eng. -A.T. -Can. -Fed.	1/4	1/32	1/2 ⁴	5/64	9/32	—	3/32	See Text	5/64	750	1600
		1/4	1/32	1/2	5/64	9/32	—	1/8	See Text	5/64	730	1500
		1/4	1/32	1/2 ⁵	—	9/32	—	1/8	See Text	5/64	600	1400
1980	225 Eng. -Can. & Fed. 318 Eng. -A.T. -Can. & Fed. 360 Eng. -A.T. -Can. & Fed.	1/4	1/32	1/2	5/64	9/32	—	3/32	—	5/64	*	1600
		1/4	1/32	1/2	5/64	9/32	—	1/8 ⁶	—	5/64	*	1500 ⁷
		1/4	1/32	1/2	5/64	9/32	—	7/64	—	5/64	*	1500
1979	225 Eng. -A.T. -Can. & Fed. 318 Eng. -A.T.	1/4	9	15/32	5/64	9/32	—	7/64	—	5/64	*	*
		1/4	9	15/32	5/64	9/32	—	7/64	—	5/64	*	*
1978	225 Eng. -A.T. -M.T. 318 Eng. -A.T. -M.T.	1/4	9	1/2	5/64	9/32	—	3/32	—	5/64	—	1600
		1/4	9	1/2	5/64	9/32	—	7/64	—	5/64	—	1500
		1/4	9	1/2	5/64	9/32	—	9/64	—	5/64	—	1500
		1/4	9	1/2	5/64	9/32	—	5/32	—	5/64	—	1400

SPECIFICATIONS BY APPLICATION (Cont'd)

Year	MODEL	Float Level Fig. A	Step-Up Piston Adjust. Fig. B	Pump Travel Fig. C	Bowl Vent Fig. D	Un- loader Fig. E	Auto. Choke Setting Fig. F	Choke Diaph. Link Fig. G	Dash- pot Fig. I	Fast Link Fig. I	Idle Speed	
											Hot	Fast

CHRYSLER, DODGE, PLYMOUTH (Cont'd) — SPECIFICATION I.D.-C

1977	225 Eng. -A.T.	1/4	9	15/32	—	9/32	—	7/64	—	5/64	750	1600
	-Calif.	1/4	9	15/32	—	9/32	—	1/8	—	5/64	850	1700
	-M.T.	1/4	9	15/32	—	9/32	—	3/32	—	5/64	750	1600
	-Calif.	1/4	9	15/32	—	9/32	—	1/8	—	5/64	800	1600
	318 Eng. -A.T. -Carb. No. 8126S	1/4	9	15/32	—	5/16	—	7/64	—	5/64	850	1500
	-Carb. No. 8094S	1/4	9	1/2	—	5/16	—	5/64	—	5/64	700	1400
	-Calif.	1/4	9	15/32	—	5/16	—	7/64	—	5/64	850	1500
	-M.T.	1/4	9	15/32	—	5/16	—	1/8	—	5/64	700	1400
-Export	1/4	9	1/2	—	9/32	—	9/64	—	5/64	—	—	
1976	318 Eng. -A.T. -Exc. Calif.	1/4	9	1/2	—	31/32	—	5/64	See Text	5/64	750	1500 ¹⁹
	-Calif.	1/4	9	1/2	—	5/16	—	7/64	See Text	5/64	750	1500 ¹⁹
	-Reg. Fuel, Air Pump	1/4	9	15/32	—	5/16	—	7/64	See Text	5/64	750	1500 ¹⁹
	-M.T.	1/4	9	1/2	—	9/32	—	1/8	See Text	5/64	750	1500 ¹⁹
1975	318 Eng. -A.T. -Exc. Calif. -Early	1/4	9	1/2	—	5/16	—	7/64	See Text	5/64 ¹⁹	650	1500 ¹⁹
	-Late	1/4	9	1/2	—	5/16	—	5/64	See Text	5/64 ¹⁹	750	1500 ¹⁹
	-Calif.	1/4	9	1/2	—	5/16	—	7/64	See Text	5/64 ¹⁹	750	1500 ¹⁹
	-M.T.; Can. -A.T.	1/4	9	1/2	—	9/32	—	1/8	See Text	5/64 ¹⁹	750	1500 ¹⁹
1974	318 Eng. -A.T. -(Exc. Calif. -Late; Export)	1/4	9	1/2	—	9/32	—	7/64	—	3/32	750	1500
	-(Calif. -Late; Export)	1/4	9	1/2	—	9/32	—	7/64	—	3/32	—	—
	-M.T. -(Exc. Export)	1/4	9	1/2	—	9/32	—	9/64	—	3/32	750	1700
	-Carb. 6464, 6466	1/4	9	1/2	—	9/32	—	9/64	—	3/32	—	—
	-Carb. 8009	1/4	9	1/2	—	9/32	—	9/64	—	3/32	—	—
-(Export)	1/4	9	1/2	—	9/32	—	5/32	—	3/32	—	—	

DODGE TRUCK

85-84	318 Eng. -Fed.	1/4	1/32	15/32	5/64	9/32	—	1/8	See Text	5/64	—	—
	-Carb. No. 8386 -Can.	1/4	1/32	15/32	5/64	5/16	—	5/64	See Text	5/64	—	—
83-82	225 Eng. -Carb. No. 8352	1/4	1/32	1/2	5/64	5/16	—	1/8	See Text	5/64	—	—
	-Carb. No. 8371	1/4	1/32	15/32	5/64	9/32	—	1/8	See Text	5/64	—	—
	318 Eng. -Carb. No. 8348	1/4	1/32	1/2	5/64	5/16	—	1/8	See Text	5/64	—	—
	-Carb. No. 8358, 59, 74	1/4	1/32	15/32	5/64	9/32	—	1/8	See Text	5/64	—	—
79-78	225 Eng. -Calif., Fed.	1/4	9	1/2	—	9/32	—	7/64	See Text	5/64	—	—
	-Carb. No. 8176	1/4	9	1/2	—	5/16	—	5/64	See Text	5/64	—	—
	318 Eng. -Fed.	1/4	9	1/2	—	9/32	—	7/64	See Text	5/64	—	—
	-Carb. Nos. 8146, 47, 56	1/4	9	1/2	—	5/16	—	7/64 ¹⁰	See Text	5/64	—	—
80-76	245, 318 Eng. -Australia	1/4	9	1/2	—	—	—	—	—	—	—	—
77-74	225 Eng. -Carb. No. 8110	1/4	9	1/2	—	9/32	—	3/32	—	5/64	—	—
	318 Eng. -Carb. No. 6536, 6610, 13, 8008	1/4	9	1/2	—	9/32	—	5/32	—	3/32	—	—
	-Carb. No. 6537, 6611	1/4	9	1/2	—	9/32	—	7/64	—	3/32	—	—
	-Carb. No. 8081, 82, 85; 8115, 46	1/4	9	1/2	—	9/32 ¹¹	—	1/8 ¹²	—	5/64	—	—
	-Carb. No. 8108, 12, 13, 21, 47	1/4	9	1/2	—	5/16	—	5/64 ¹³	—	5/64	—	—
	-Carb. No. 8013, 14, 16, 20, 24, 25, 26	1/4	9	1/2	—	5/16 ¹⁴	—	1/8 ¹⁵	—	5/64	—	—
	-Carb. No. 6585, 86	1/4	9	1/2	—	—	—	—	—	5/64	—	—

FOOTNOTES

- ¹ Carb. Nos. 8360, 62, 64, 67 - gold index key, set Index; red index key, set 1 Rich; green index key, set 2 Rich.
- ² Carb. No. 8341 set 5/32.
- ³ Carb. No. 8351 set Index.
- ⁴ 1983 Carb. No. 8290 set 15/32.
- ⁵ 1983 Carb. No. 8291 set 15/32.
- ⁶ Carb. No. 8317 set 9/64.
- ⁷ Carb. No. 8235 set 1700 RPM.
- ⁸ Refer to decal in engine compartment.
- ⁹ Perform Step II, Fig. B.
- ¹⁰ Carb. No. 8147 set 5/32; Carb. No. 8146 set 5/64.
- ¹¹ Compact & Voyager models set 5/16.
- ¹² Carb. No. 8081 set 5/32; Carb. No. 8146 set 5/64.

- ¹³ Carb. No. 8108 set 5/32; Carb. No. 8112 set 7/64; Carb. No. 8113 set 1/8.
- ¹⁴ Carb. No. 8020, 24 set 9/32.
- ¹⁵ Carb. No. 8014, 26 set 7/64; Carb. No. 8025 set 5/64.
- ¹⁶ Adjust with Choke Valve wide open.
- ¹⁷ Throttle fully closed.
- ¹⁸ AMC only with idle speed set and throttle lever in Idle position, push dashpot plunger into end of travel. Check clearance between throttle lever and end of plunger. Clearance must be as specified (see specification chart). To adjust, rotate dashpot in bracket.
- ¹⁹ Set idle speed screw on second cam against shoulder of first.

ABBREVIATIONS

A/T	Automatic Transmission
M/T	Manual Transmission
Calif.	California
Can.	Canada
Exc.	Except
Fed.	Federal (49 States)
Hi-Alt.	High Altitude